

名称	型号	图形	分度号	温度范围	页码
热电阻内芯	WZP-010 WZC-010				7
无固定式	WZP-130 WZC-130				7
固定螺纹式	WZP-230 WZC-230	 M27*2			8
活动法兰式	WZP-330 WZC-330				8
固定法兰式	WZP-430 WZC-430	 DN15			9
整体打孔锥形 保护管式	WZP-630 WZC-630	 M33*2	Pt100	-200~+420℃	9
活动螺纹式	WZP-730 WZC-730	 M27*2	Pt200 Pt500	-200~+420℃ -200~+420℃	10
无固定式	WZP-1312 WZC-1312	 φ8	Pt1000 Cu50	-200~+420℃ 0~150℃	11
固定螺纹式	WZP-2312 WZC-2312	 φ8	Cu100	0~150℃	12
活动法兰式	WZP-3312 WZC-3312	 φ8			12
固定法兰式	WZP-4312 WZC-4312	 φ8			12
固定螺纹式	WZP-280 WZC-280	 φ8			11

Pt100为最常用类型

## 装配式热电阻 Packaged thermal resistance

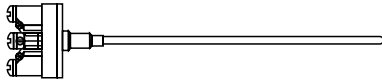
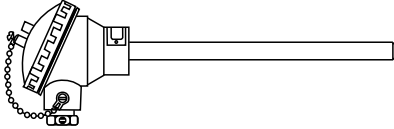
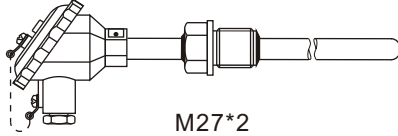
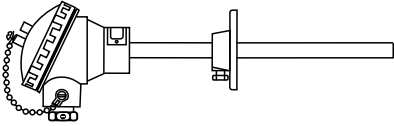
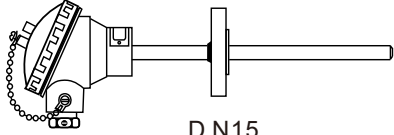
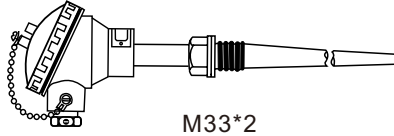
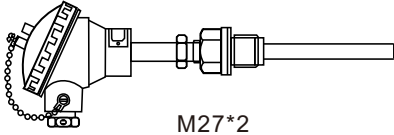
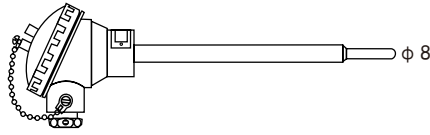
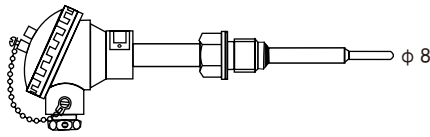
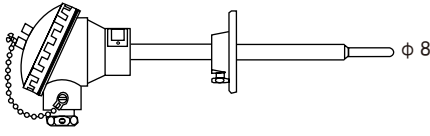
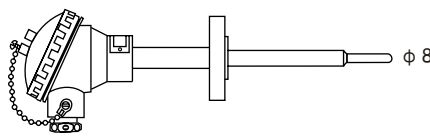
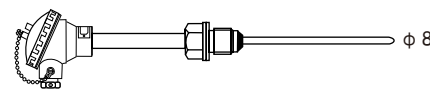

工业用热电阻分铂热电阻和铜热电阻两大类。

Industrial thermal resistance contains two categories, Pt thermal resistance and Copper thermal resistance.

热电阻是利用物质在温度变化时自身电阻也随着发生变化的特性来测量温度的。热电阻的受热部分（感温元件）是用细金属丝均匀地双绕在绝缘材料制成的骨架上。当被测介质中有温度梯度存在时，所测得的温度是感温元件所在范围内介质层中的平均温度。

Thermal resistance is used to measure temperature on the basis of the property that substances' own resistance varies with the temperature. The part of the thermal resistance that is heated (temperature-sensing element) is made by dual winding of fine wires around the frame made of insulation materials. When there is temperature gradient in the mediums to be measured, the measured temperature is the average temperature in the dielectric layer within the range where the temperature-sensing element is placed.

装配式热电阻主要由接线盒、保护管、接线端子、绝缘套管和感温元件组成，并配以各种安装固定装置。

Packaged thermal resistance consists of connection box, protectin tube, connection terminal, insulating sleeve and various fixed devices.

WZP型铂电阻的感温元件是一个铂丝绕组，双支铂电阻主要用于需要用二次显示、记录或调节仪同时检测同一地点温度的场合。WZC型铜电阻的感温元件是一个铜丝绕组。

WZP Pt resistance's temperature-sensing element is a Pt wire winding. Double platinum resistance mainly is used fou such situation where it is required to use secondary display instrument, recorder and accomodometer to simultaneously detect the temperature of the same place. WZC copper resistance's temperature-snesing element is a copper wire winding.

### 热电阻测温原理

### Temperature measurement principle of thermal resistance

受热后的金属丝电阻随着温度的变化而变化，其热电阻值R(t)与其所处温度t的关系可表示为： $R(t)=R_0(1+At+Bt^2+-----)$

按测得的电阻值查相应分度号表即可得出被测温度值t。或由显示仪表直接读出。

The resistance of the metal wire that has been heated varies with the temperature, and the relation between the thermal resistance value and the temperature it is at can be expressed as  $R(t)=R_0((1+At+Bt^2+-----)$

According to the resistance value that is measured to refer to corresponding graduation mark, the temperature t that is measured can be come out, or read it directly from the indicating instrument.

## 热电阻基本结构 Basic structure of thermal resistance

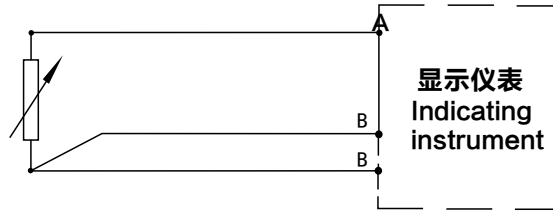

热电阻测温原理  
Measuring Principle Of RTD

## 主要技术指标 Major technical indexes

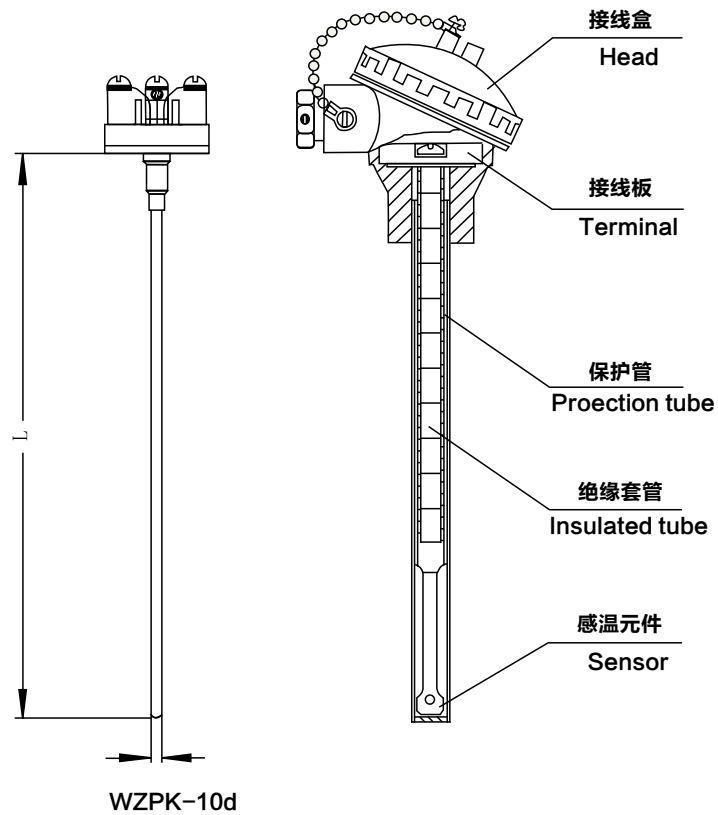

## 热电阻类型，测量范围与允差 Thermal resistance type, Measuring range and tolerance

类型 Type	代号 Code	分度号 Graduation mark	测量范围 Measurement range (°C)	允许偏差 $\Delta t$ (°C) Tolerance
铂热电阻 Platinum thermal resistance	WZP	Pt100	-200~+450	AA级: (-50~+250) $\pm(0.100+0.0017 t )$
			-200~+450	A级: (-100~+450) $\pm(0.150+0.002 t )$
铂热电阻 Platinum thermal resistance	WZP	Pt100	-200~+600	B级: (-196~+600) $\pm(0.30+0.005 t )$
			-200~+600	C级: (-196~+600) $\pm(0.60+0.010 t )$
铜热电阻 Copper thermal resistance	WZC	Cu100	-50~+150	$\pm(0.30+0.006 t )$

注：(1) 其中“|t|”为感温元件的实测温度的绝对值。

- (2) 陶瓷骨架铂热电阻元件测量范围-200~+850°C。
- (3) 云母骨架铂热电阻元件测量范围-200~+420°C。
- (4) 厚膜铂热电阻元件、薄膜铂热电阻元件测量范围-70~600°C。

Note: (1) Of which, “|t|” is the absolute value of the measured temperature of the temperature-sensing element.  
 (2) The Measuring range of the thermal resistance element with pottery frame is 200~+850°C.  
 (3) The Measuring range of the thermal resistance element with mica frame is -200~+420°C.  
 (4) The Measuring range of the thick-film Pt thermal resistance element and the thin-film Pt thermal resistance element is -70~600°C.

## 热电阻感温元件 Temperature-sensing element of thermal resistance

(图42 Fig 42)

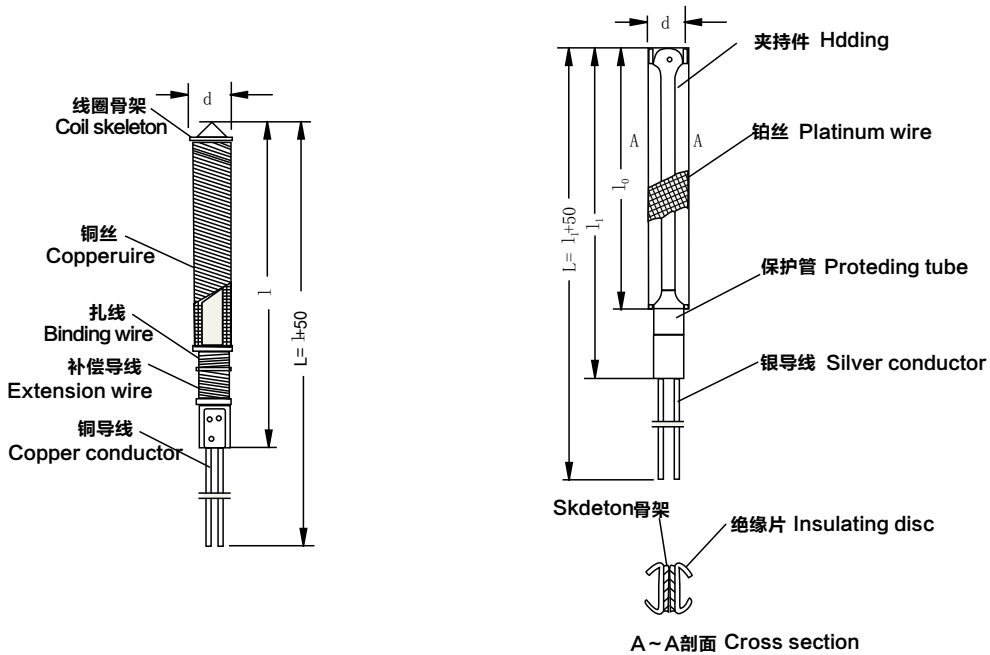

铜电阻感温元件

铂电阻感温元件

## Temperature-sensing element of copper resistance Temperature-sensing element of Pt resistance

### 热响应时间 Thermal response time

在温度发生阶跃变化时，热电阻的输出变化至相当于该阶跃变化的50%，所需要的时间称为热响应时间，用  $\tau_{0.5}$  表示，实验介质通常为水。

When the temperature shown step changes, the output variation of the thermal resistance shall be at least equivalent to 50% of the variation, and the time that needs is thermal response time, denoted as  $\tau_{0.5}$ . The experimental medium is usually water.

### 公称压力 Nominal pressure

一般是指在常温下保护管所能承受的静态外压力而不破损、泄露。允许工作压力不仅与温度、保护管材料、直径、壁厚等有关，还与其结构形式、安装方法、插入深度以及被测介质种类和流速等有关。

It usually indicates the static external pressure the protection tube is capable of bearing under the room temperature while the protection

# 上仪 南浦 专注温度测量与控制

tube does not break or leak. In fact, the safe working pressure is not only related to temperature, materials of protection tube and wall thickness and diameter, but also related to structural configuration, assembling method, placed depth, medium type and flow rate to be measured.

### 热电阻最小置入深度

一般不小于100mm（特殊产品除外）。

The minimum placed depth of thermal resistance shall be not less than 100mm (except the special products).

### 热电阻绝缘电阻Insulation resistance of thermal resistance

常温绝缘电阻值的试验电压可取直流10~100V任意值。环境温度在15~35℃范围内，相对湿度应不大于80%，铂热电阻的常温绝缘电阻值应不小于100MΩ。铜热电阻的常温绝缘电阻应不小于50 MΩ。

The experimental voltage of insulation resistance at normal temperature can be selected from any value from DC 10V to 100V. The normal-temperature insulation resistance of Pt thermal resistance shall not less than 100MΩ, if the ambient temperature is within the range of 15~35℃ and the relative humidity is not more than 80%, while that of the copper thermal resistance shall not less than 50 MΩ.

### 自然影响Natural influence

热电阻允许通过的最大测量电流为2~5mA（根据不同元件），由此产生的温升不大于0.3℃。

the maximum measuring current that is permissible to pass through the thermal resistance is 2~5mA( depending on different elements), from which, the temperature rise arose shall not exceed 0.3℃.

## 型号命名Type designation

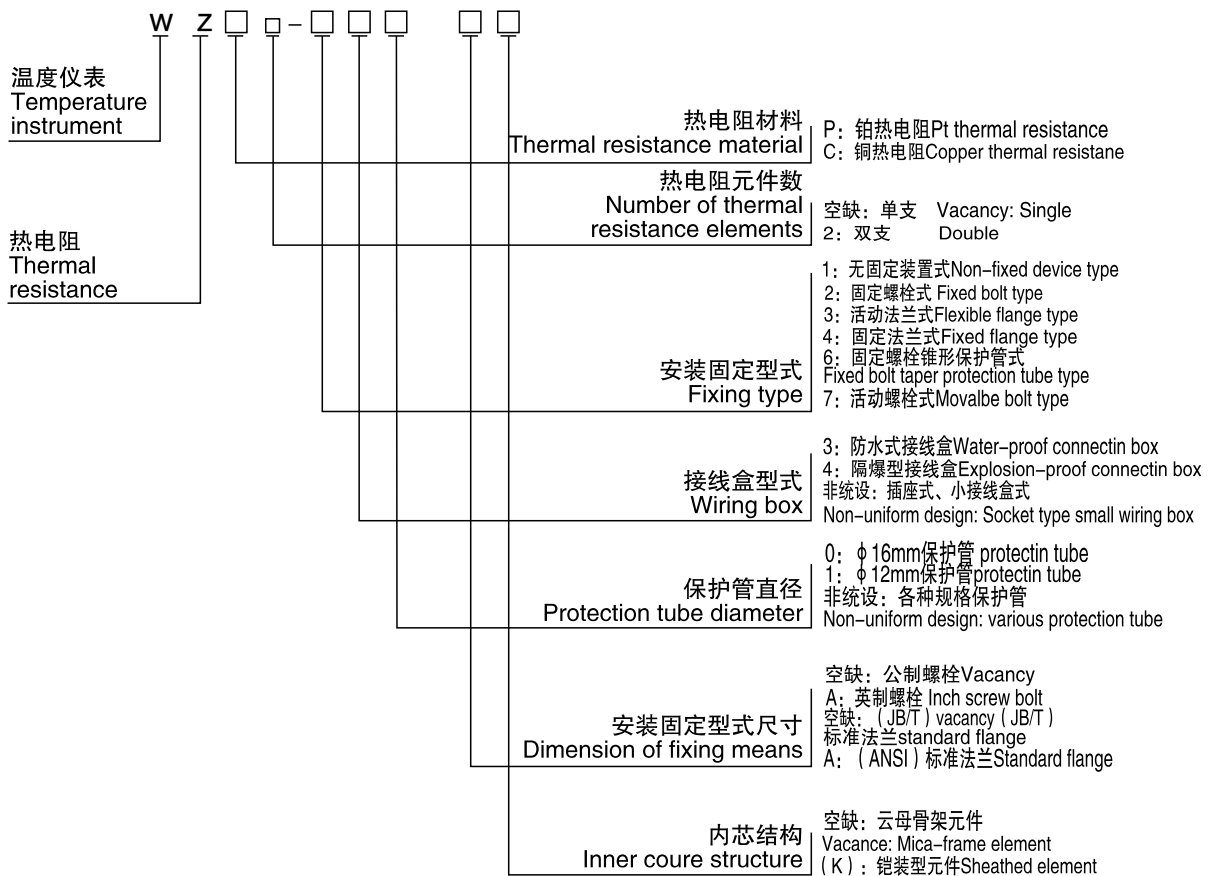

## 热电阻感温元件 Temperature-sensing element of thermal resistance

型号Type	分度号 Graduation mark	测量范围 Measuring range (°C)	热响应时间 Thermal response time $\tau \leq 0.5(s)$	规格Specification			
				d	L	$l_0$	$l_1$
WZP-010 WZP <sub>2</sub> -010	Pt100	-200~+420	$\leq 60$	$\phi 12$	300 900	85	105
450 1400					550 1650		
WZP-011 WZP <sub>2</sub> -011	Pt100	-200~+420	$\leq 30$	$\phi 8$	300 900	65	80
450 1400					550 1650		
WZC-010A	Cu50	-50~+100	$\leq 90$		300 900	90	105

注：(1) 可作为普通型铂热电阻的内芯进行更换。(2) WZP-010、011为元母骨架元件。(3) WZC-010为铜电阻元件。  
 Note: (1) It can be changed with the inner core of conventional type platinum thermocouple. (2) WZP-010 and 011 are skeleton elements. (3) WZC-010 is copper resistance element.

## 铂电阻元件 Pt resistance element

型号Type	分度号 Graduation mark	热响应时间 Thermal response time $\tau \leq 0.5(s)$	保护管材料 Protection tube material	规格 (mm) Specification		
				d	l	s
WZP-011S	Pt100	$\leq 0.15$	陶瓷Pottery	$\phi 1.2$	20	10
WZP-012S		$\leq 0.2$		$\phi 1.6$	25	15
WZP-013S		$\leq 2$	1Cr18Ni9Ti	$\phi 3$	32	200
WZP-014S		$\leq 0.5$	陶瓷Pottery	$\phi 3.2$	25	15
WZP-015S		$\leq 5$	1Cr18Ni9Ti	$\phi 5$	32	200
WZP-203S				$\phi 3$		
WZP-205S				$\phi 5$		

注：WZP-203螺栓为M6、WZP-205螺栓为M8、S为进口元件。  
 Note: WZP-230S bolt is M6, WZP-250 bolt is M8 and S indicates imported elements.

## 端面型热电阻元件 End-face thermal resistance element

型号Type	分度号 Graduation mark	测量范围 Measuring range (°C)	热响应时间 Thermal response time $\tau \leq 0.5(s)$	保护管材料 Protection tube material	规格 (mm) Specification		
					d	H	S
WZPM-018	Pt100	-200~+500	$\leq 0.5$	陶瓷Pottery	$\phi 8$	2	15
WZPM-0110		-50~+150	$\leq 5$	1Cr18Ni9Ti	$\phi 10$	8	200
WZPM-2012		$\leq 10$	M		10	200	

## 薄膜型铂热电阻元件 Thin-film Pt thermal resistance element

型号Type	分度号 Graduation mark	测量范围 Measuring range (°C)	规格 (mm) Specification		
WZP-2105	Pt 100	-50~+500	L	W	H
WZP-2108			2.3	2	1.3
WZP-2105M			1.6	1.25	1.1
			2.3	2	1.4

## 厚膜型铂热电阻元件 Thick-film Pt thermal resistance element

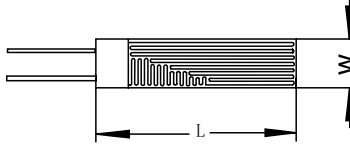
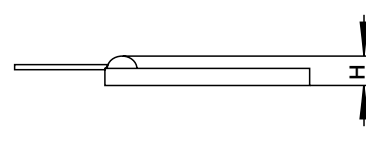
型号 Type	分度号 Graduation mark	测量范围 Measuring range (°C)	规格 (mm) Specification				
			L	W	H		
WZP-08A	Pt 100 (Pt 500) (Pt1000)	-50~+500 (-50~+400)	25	3.2	1.8		
WZP-08B			15	2	1.5		

## 金属护套铂热电阻元件 Metallic sheath Pt thermal resistance element

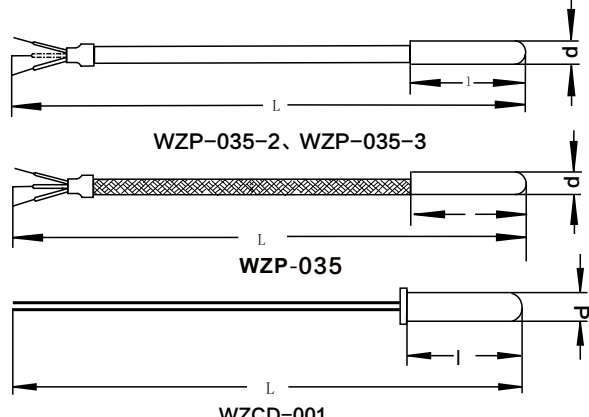
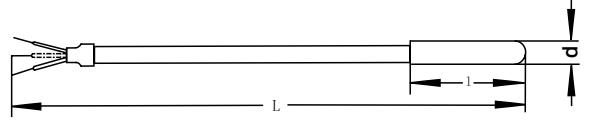
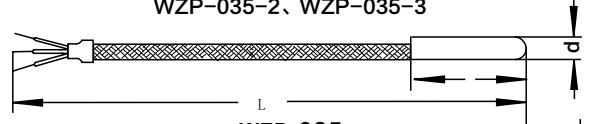
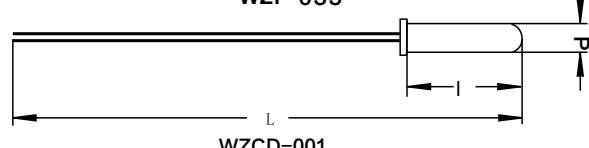
型号 Type	分度号 Graduation mark	测量范围 Measuring range (°C)	热响应时间 Thermal response time $\tau_{0.5}(s)$	保护管材料 Protection tube material	规格规格 Specification			
					d	L	I	
WZP-035 WZP <sub>2</sub> -035	Pt100	-200~+260	≤5	1Cr18Ni9TI	φ3 φ4 φ5 φ6 φ8	500	10	 WZP-035-2, WZP-035-3
1000						20		
1500						25		
2000						30		
WZP-035-3 WZP <sub>2</sub> -035-3						2500	40	 WZP-035
						3000	50	
WZP-001-4 WZP <sub>2</sub> -001-4						3500	80	 WZCD-001
						4000	100	
WZCD-001-1 WZCD-001-2 WZCD-001-3 WZCD-001-4	CU50	-50~+100	≤30	T2				

注：(1) 主要用于推力瓦温度测量。

(2) 型号后加-1 为三线制带屏蔽导线，型号后加-2为二线制无屏蔽带耐油护套导线；型号后加-3为三线制无屏蔽带耐油护套导线，型号后加-4为三线制带屏蔽、耐油护套导线、引出线类型可根据用户要求选定。

(3) 引出线长度超过5m为四线制。

Note: (1) They are mainly used to measure the temperature for thrust block.

(2) The type with -1 is three-wire system shielded conductor, and that with -2 is two-wire system unshielded conductor with oil-proof sheath, and that with -3 is three-wire system unshielded conductor with oil-proof sheath and that with -4 is three-wire system shielded conductor with oil-proof sheath. The type for leading-out wire can be selected as the users required.

(3) The leading-out wire over 5m is four-wire system.

## 简易式铂热电阻元件 (带瓷接线板) Simple Pt thermal resistance element (with magnetic terminal block)

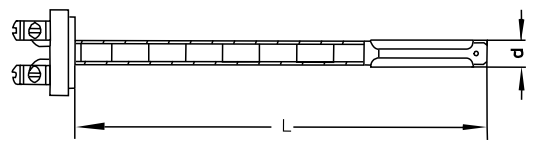
型号 Type	分度号 Graduation mark	测量范围 Measuring range (°C)	热响应时间 Thermal response time $t_{0.5}(s)$	骨架材料 Frame material	规格 (mm) Specification		
					d	L	
WZP-010 WZP <sub>2</sub> -010	PT100	-200~+420	≤60	云母 mica	φ12	280~2180	
WZP-011 WZP <sub>2</sub> -011			≤30		φ8		

注：(1) 主要用于装配式铂热电阻内芯更换。其长度正确选用应为外保护管总长度“L”再增加30mm。例：外保护管L=900mm，其内芯长度应为：930mm。

(2) 接线端子规格

(3) L可根据用户需求选定。

Note: (1) The length selected shall be the overall length “L” of the outer protecting tube plus 30mm. For example: if the outer protecting tube L= 900mm, then its inner core shall be 930mm.istance.

(2) The specification of the connection terminal can be referred

(3) L can be chosen as the users required.



## 简易式铠装铂热电阻元件（带瓷接线板）

### Simple sheathed Pt thermal resistance element (with magnetic terminal block)

型号Type	分度号 Graduation mark	测量范围 Measuring range (°C)	热响应时间 Thermal response time $\tau$ 0.5(s)	保护管材质 Protection tube material	规格(mm) Specification		
					d	L	
WZPK-103	Pt100	-70~+600	$\leq 3$	1Cr18Ni9Ti	$\phi 3$	280~2180	
WZPK-104 WZPK <sub>2</sub> -104			$\leq 5$		$\phi 4$		
WZPK-105 WZPK <sub>2</sub> -105			$\leq 8$		$\phi 5$		
WZPK-106 WZPK <sub>2</sub> -106			$\leq 12$		$\phi 6$		

注：（1）用于装配式铠装铂热电阻内芯更换。

（2）L可根据用户需求选定。

Note: (1) They are mainly used to replace the inner core of sheathed Pt thermal resistance.

(2) L can be chosen as the users required.

## 热电阻保护管直径和长度规格

### Diameter and length specification of thermal resistance protection tube

d(mm) $\phi 12$	总长L(mm) Overall length	225	250	300	350	400	450	550	650	900	1150	1400	1650
	置入深度l (mm) Placed depth	75	100	150	200	250	300	400	500	750	1000	1250	1500

d(mm) $\phi 16$	总长L(mm) Overall length	225	250	300	350	400	450	550	650	900	1150	1400	1650	2150
	置入深度l (mm) Placed depth	75	100	150	200	250	300	400	500	750	1000	1250	1500	2000

## 结构型式Structural shape

### 无固定装置式热电阻Non-fixed device thermal resistance

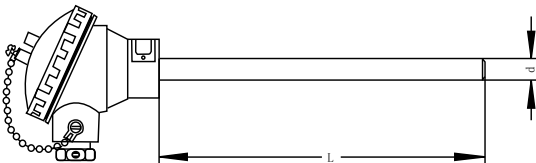
型号Type	分度号 Graduation mark	测量范围 Measuring range (°C)	热响应时间 Thermal response time $\tau$ 0.5(s)	保护管材料 Protection tube material	d(mm)	
WZP-130 WZP <sub>2</sub> -130	Pt100	-200~+420	$\leq 90$	1Cr18Ni9Ti	$\phi 16$	
WZP-130(K) WZP <sub>2</sub> -130(K)		-70~+600	$\leq 45$			
WZP-131 WZP <sub>2</sub> -131		-200~+420	$\leq 60$			
WZP-131(K) WZP <sub>2</sub> -131(K)		-70~+600	$\leq 30$			
WZC-130 WZC-130(K)	Cu50	-50~+100	$\leq 120$		$\phi 12$	

注：（1）型号后加（K），内芯为铠装元件。

（2）热电阻保护管直径和长度规格。

Note: (1) Of the type immediately followed with (K), the inner core is sheathed element.

(2) Refer for the diameter and length of the thermal resistance protection tube.



**固定螺栓式热电阻 Fixed bolt thermal resistance**

型号 Type	分度号 Graduation mark	测量范围 Measuring range (°C)	热响应时间 Thermal response time ±0.5(s)	保护管材料 Protection tube material	d(mm)
WZP-230 WZP <sub>2</sub> -230	Pt100	-200~+420	≤90	1Cr18Ni9Ti	φ16
WZP-230A WZP <sub>2</sub> -230A					
WZP-230(K) WZP <sub>2</sub> -230(K)		-70~+600	≤45		φ12
WZP-231 WZP <sub>2</sub> -231		-200~+420	≤60		
WZP-231A WZP <sub>2</sub> -231A					
WZP-231(K) WZP <sub>2</sub> -231(K)	-70~+600	≤30			
WZC-230 WZC-230A WZC-230(k)	Cu50	-50~+100	≤120		

- 注：(1) 公称压力：10Mpa。  
 (2) 型号后加(K)，内芯为铠装元件。  
 (3) 型号后加A为英制G3/4螺栓。  
 (4) 选用英制G3/4螺栓，内芯为铠装元件。例：WZP-230A(K)  
 (5) 直形保护管的固定螺栓规格。

- Note: (1) Nominal pressure: 10Mpa  
 (2) Of the type immediately followed with (K), the inner core is sheathed element.  
 (3) Of the type immediately followed with A, it is the British system G3/4 bolt.  
 (4) Those that are of British system G3/4 bolt and have sheathed element as the inner core shall be selected. For example: WZP-230A(K).  
 (5) Refer for the fixed bolt specification of straight protection tube.

**活动法兰式热电阻 Flexible flange thermal resistance**

型号Type	分度号 Graduation mark	测量范围 Measuring range (°C)	热响应时间 Thermal response time ±0.5(s)	保护管材料 Protection tube material	d(mm)
WZP-330 WZP <sub>2</sub> -330	Pt100	-200~+420	≤90	1Cr18Ni9Ti	φ16
WZP-330(K) WZP <sub>2</sub> -330(K)		-70~+600	≤45		
WZP-331 WZP <sub>2</sub> -331		-200~+420	≤60		φ12
WZP-331(K) WZP <sub>2</sub> -331(K)		-70~+600	≤30		
WZC-330 WZC-330(K)	Cu50	-50~+100	≤120		

- 注：(1) 公称压力为常压。  
 (2) 型号后加(K)，内芯为铠装元件。  
 (3) 活动法兰规格。

- Note: (1) Nominal pressure is the normal pressure.  
 (2) Of the type immediately followed with (K), the inner core is sheathed element.  
 (3) Refer for specification of the flexible flange.

## 固定法兰式热电阻 Fixed flange thermal resistance

型号 Type	分度号 Graduation mark	测量范围 Measuring range (°C)	热响应时间 Thermal response time $\tau$ 0.5(s)	保护管材料 Protection tube material	d(mm)	
WZP-430 WZP <sub>2</sub> -430	Pt100	-200~+420	≤90	1Cr18Ni9Ti	φ16	
WZP-430(K) WZP <sub>2</sub> -430(K)		-70~+600	≤45			
WZP-431 WZP <sub>2</sub> -431		-200~+420	≤60		φ12	
WZP-431(K) WZP <sub>2</sub> -431(K)		-70~+600	≤30			
WZC-430(K) WZC <sub>2</sub> -430(K)	Cu50	-50~+100	≤120			

- 注：(1) 公称压力：2.5Mpa。  
 (2) 型号后加A，为ANSI标准法兰。例：WZP-430A。选用JB/T标准法兰。  
 (3) 型号后加(K)内芯为铠装元件。  
 (4) 热电阻保护管直径和长度规格。

- Note: (1) Nominal pressure: 2.5Mpa.  
 (2) The type immediately followed with A is ANSI standard flange, for example, WZP-430A. Refer to select the JB/T standard flange.  
 (3) Of the type immediately followed with (K), the inner core is sheathed element.  
 (4) Refer for the diameter and length of the thermal resistance protection tube.

## 固定螺栓锥形保护管式铂热电阻 Fixed bolt taper protection tube Pt thermal resistance

型号 Type	分度号 Graduation mark	测量范围 Measuring range (°C)	热响应时间 Thermal response time $\tau$ 0.5(s)	保护管材料 Protection tube material	规格 Specification (mm)	
WZP-630(K) WZP <sub>2</sub> -630(K)	Pt100	-70~+600	≤60	1Cr18Ni9Ti	L × l	
WZP-630A(K) WZP <sub>2</sub> -630A(K)					250 × 100 300 × 150 350 × 200 400 × 250 450 × 300 500 × 350 550 × 400 600 × 450 650 × 500	
WZP-631B(K) WZP <sub>2</sub> -631B(K)						

- 注：(1) 公称压力：30 Mpa。流速 ≤80m/s。  
 (2) 型号后加(K)，内芯为铠装元件。例：WZP-630(K)  
 (3) 选用英制G1”螺栓，内芯为铠装元件，应在型号后加A(K)。例：WZP-630A(K)  
 (4) 选用齿形垫片，应在型号后加B，例：WRN-630B(K)。  
 (5) 锥形保护管固定螺栓。

- Note: (1) Nominal pressure: 30 Mpa. Flow rate ≤80m/s.  
 (2) Of the type immediately followed with (K), the inner core is sheathed element. For example, wzp-630 (K)  
 (3) Those that are of British system G1 bolt and have sheathed element as the inner core shall be added A (K) after the type when are selected. For example: WZP-630A (K) .  
 (4) Grooved metal gasket that is selected shall mark B behind the type, for example, WRN-630B (K). Refer for the specification of grooved metal gasket.  
 (5) Refer for taper protection tube fixed bolt.

## 活动螺栓式铂热电阻 Movable bolt Pt thermal resistance

型号 Type	分度号 Graduation mark	测量范围 Measuring range (°C)	热响应时间 Thermal response time $\tau$ 0.5(s)	保护管材料 Protection tube material	d(mm)
WZP-730 WZP <sub>2</sub> -730	Pt100	-200~+420	≤90	1Cr18Ni9Ti	φ16
WZP-730(K) WZP <sub>2</sub> -730(K)		-70~+600	≤45		
WZP-731 WZP <sub>2</sub> -731		-200~+420	≤60		φ12
WZP-731(K) WZP <sub>2</sub> -731(K)		-70~+600	≤30		



- 注：(1) 公称压力为常压。  
 (2) 型号后加 (K)，内芯为铠装元件。  
 (3) 热电阻保护管直径和长度规格。  
 (4) 直形保护管的固定螺栓规格。

Note: (1) The nominal pressure is normal pressure.  
 (2) Of the type immediately followed with (K), the inner core is sheathed element.  
 (3) Refer for the diameter and length specification of the thermal resistance protection tube.

## 固定螺栓带导线式热电阻 Fixed bolt lead thermal resistance

型号 Type	分度号 Graduation mark	测量范围 Measuring range (°C)	热响应时间 Thermal response time $\tau$ 0.5(s)	保护管材料 Protection tube material	规格 Specification (mm)
WZP-200(K)	Pt100	-70~+400	≤30	1Cr18Ni9Ti	L × I 500×100 550×150 600×200 700×300 900×400
WZP <sub>2</sub> -200(K)			≤45		
WZC-200(K)	Cu50	-50~+100	≤120		

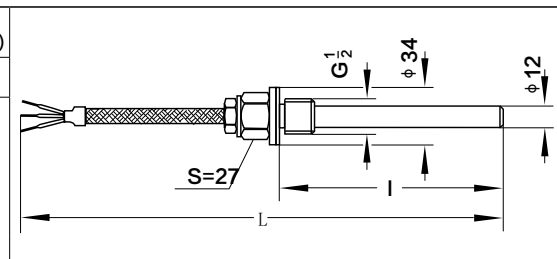

## 可动螺栓表面式铂热电阻 Movable bolt surface platinum thermistor resistance

型号 Type	分度号 Graduation mark	测量范围 Measuring range (°C)	热响应时间 Thermal response time $\tau$ 0.5(s)	保护管材料 Protection tube material	规格 Specification (mm)
WZPM-267	Pt100	-70~+400	≤30	1Cr18Ni9Ti	L 100 150 200 250 300 350
WZPM <sub>2</sub> -267					

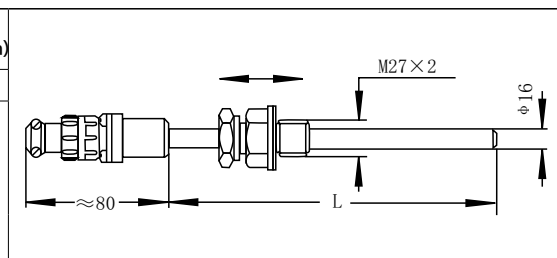

## 管螺栓固定螺栓插座式热电阻 Pipe bolt fixed bolt socket thermal resistance

型号 Type	分度号 Graduation mark	测量范围 Measuring range (°C)	热响应时间 Thermal response time $\tau$ 0.5(s)	保护管材料 Protection tube material	规格 Specification (mm)
WZP-269	Pt100	-200~+420	≤30	1Cr18Ni9Ti	L 75 100 150 200 250
WZP <sub>2</sub> -269			≤45		
WZC-269	Cu50	-50~+100	≤120		

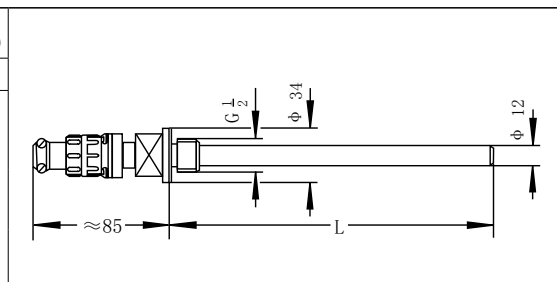

**固定螺栓插座式铂热电阻 Fixed bolt socket platinum thermal resistance**

型号 Type	分度号 Graduation mark	测量范围 Measuring range (°C)	热响应时间 Thermal response time $\tau$ 0.5(s)	保护管材料 Protection tube material	规格 Specification (mm)	
					L	
WZP-270	Pt100	-70~+400	$\leq 15$	1Cr18Ni9Ti	40	
WZP <sub>2</sub> -270			$\leq 30$		50	
				75		
				100		
					150	

**固定螺栓带导线式铂热电阻 (汽机专用) Fixed bolt lead platinum thermal resistance (special for steam machine)**

型号 Type	分度号 Graduation mark	测量范围 Measuring range (°C)	热响应时间 Thermal response time $\tau$ 0.5(s)	保护管材料 Protection tube material	规格 Specification (mm)	
					L	S
WZP-SQ1	Pt100	0~100	$\leq 15$	1Cr18Ni9Ti	75	
WZP <sub>2</sub> -SQ1			$\leq 30$		2000	

**固定螺栓式铂热电阻 Fixed bolt platinum thermal resistance**

型号 Type	分度号 Graduation mark	测量范围 Measuring range (°C)	热响应时间 Thermal response time $\tau$ 0.5(s)	保护管材料 Protection tube material	规格 Specification (mm)	
					L x l	
WZP-280	Pt100	-70~+400	$\leq 30$	1Cr18Ni9Ti	175 × 75	
WZP <sub>2</sub> -280			$\leq 45$		200 × 100	
				250 × 150		
				300 × 200		
					350 × 250	

**固定螺栓式 (蜂窝状) 铂热电阻 Fixed bolt (honeycomb) platinum thermal resistance**

型号 Type	分度号 Graduation mark	测量范围 Measuring range (°C)	热响应时间 Thermal response time $\tau$ 0.5(s)	保护管材料 Protection tube material	L (mm)
WZP-26S	PT100	-70~+400	$\leq 5$	1Cr18Ni9Ti	50 75 100 125 150

注: WZP-26S型用于测量流动气体和液体的温度。

Note: WZP-26S type is used to measure the temperature of floating gas and liquid.

**无固定装置变径式铂热电阻 Non-fixed device variable diameter platinum resistance**

型号 Type	分度号 Graduation mark	测量范围 Measuring range (°C)	热响应时间 Thermal response time $\tau$ 0.5(s)	保护管材料 Protection tube material
WZP-1312 WZP <sub>2</sub> -1312	Pt100	-70~+600	$\leq 30$	1Cr18Ni9Ti

# 上仪 南浦 专注温度测量与控制

注：(1) 内芯为铠装元件。  
 (2) 热电阻保护管直径和长度规格。  
 Note: (1) The inner core is sheathed element.

## 固定螺栓变径式铂热电阻 Fixed bolt variable diameter platinum thermal resistance

型号 Type	分度号 Graduation mark	测量范围 Measuring range (°C)	热响应时间 Thermal response time $\tau_{0.5}(s)$	保护管材料 Protection tube material	
WZP-2312 WZP <sub>2</sub> -2312	Pt100	-70~+600	≤30	1Cr18Ni9Ti	
WZP-2312A WZP <sub>2</sub> -2312A					

注：(1) 内芯均为铠装元件。(2) 直形保护管的固定螺栓规格 M27\*2 G3/4。  
 (3) 选用英制 G3/4" 螺栓，型号后加 A。例：WZP-2312A。  
 (4) 热电阻保护管直径和长度规格。  
 Note: (1) All the inner cores are sheathed elements.  
 (2) Refer for the specification of fixed bolt of the straight protection tube.  
 (3) The British system G3/4" bolt shall have A added after the type when being selected. For example, WZP-2312A.  
 (4) Refer for diameter and length specification of thermal resistance protection tube.

## 活动法兰变径式铂热电阻 Flexible flange variable diameter platinum thermal resistance

型号 Type	分度号 Graduation mark	测量范围 Measuring range (°C)	热响应时间 Thermal response time $\tau_{0.5}(s)$	保护管材料 Protection tube material	
WZP-3312 WZP <sub>2</sub> -3312	Pt100	-70~+600	≤30	1Cr18Ni9Ti	

注：(1) 内芯均为铠装元件。(2) 活动法兰规格。(3) 热电阻保护管直径和长度规格可按用户要求。  
 Note: (1) All the inner cores are sheathed elements. (2) Refer for flexible flange specification. (3) Refer for diameter and length specification of thermal resistance protection tube.

## 固定法兰变径式铂热电阻 Fixed flange variable diameter platinum thermal resistance

型号 Type	分度号 Graduation mark	测量范围 Measuring range (°C)	热响应时间 Thermal response time $\tau_{0.5}(s)$	保护管材料 Protection tube material	
WZP-4312 WZP <sub>2</sub> -4312	Pt100	-70~+600	≤30	1Cr18Ni9Ti	

注：(1) 公称压力为：2.5Mpa。(2) 内芯均为铠装元件。(3) 型号后加 A，为 ANSI 标准法兰。例：WZP-4312A。选用 JB/T 标准法兰。  
 (4) 热电阻保护管直径和长度规格。  
 Note: (1) Nominal pressure: 2.5Mpa. (2) All the inner cores are sheathed elements. (3) The type immediately followed with A is ANSI standard flange, for example, WZP-4312A. Refer to select the JB/T standard flange. (4) Refer Table for diameter and length specification of thermal resistance protection tube.

### 固定螺栓锥形保护管变径式铂热电阻

### Fixed bolt taper protectin tube variable diameter platinum thermal resistance

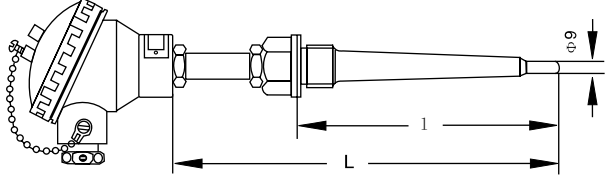
型号Type	分度号 Graduation mark	测量范围 Measuring range (°C)	热响应时间Thermal response time τ 0.5(s)	规格Specification	
				L x l	
WZP-6309 WZP <sub>2</sub> -6309	Pt100	-70~+600	≤30	250 × 100	
WZP-6309A WZP <sub>2</sub> -6309A				300 × 150	
				350 × 200	
				400 × 250	
				450 × 300	
WZP-6309B WZP <sub>2</sub> -6309B				500 × 350	
	550 × 400				
				600 × 450	
				650 × 500	

- 注：(1) 公称压力：30Mpa。流速：≤80m/s。  
 (2) 保护管材料：1Cr18Ni9Ti。  
 (3) 内芯均为铠装元件。  
 (4) 选用英制G1”螺栓，应在型号后加A，例：WZP-6309A。  
 (5) 锥形保护管的固定螺栓规格。

- Note: (1) Nominal pressure: 30 Mpa. Flow rate ≤80m/s.  
 (2) Protection tube material: 1Cr18Ni9Ti.  
 (3) All the inner cores are sheathed elements.  
 (4) Those that are of British system G1” bolt shall be added A after the type when being selected. For example: WZP-6309A.  
 (5) Refer for fixed bolt specification of taper protection tube.